

THIS IS A TWO PAGE PARTS LIST.
 THIS FIRST PAGE APPLIES TO
 MODEL 50-4085-01 AT REVISION C AND LATER REVISIONS.

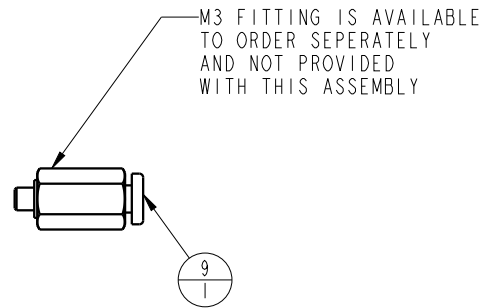

NO	QTY	PART NO	DESCRIPTION	REPAIR KIT
1	2	21500055	SCREW, CAP, BTNH, M3 X 4, SST, w/ BND WSHR	X
2	1	23350133	SPRING, COMPRESSION	X
3	1	39051025	O-RING, (-011)	X
4	1	85040002	RETAINER, SENSOR, POSITION, PNEU	
5	1	85040004	PISTON, SENSOR, POSITION, PNEU, OC	
6	2	39V00053	O-RING, (-007)	X
9	N/A	P3037020	1/8 TUBE - M3 CONNECTOR	
N/A	N/A	62504000	KIT, REPAIR	NOTED
N/A	N/A	1S5003	INSTRUCTION SHEET	

PARTS LIST

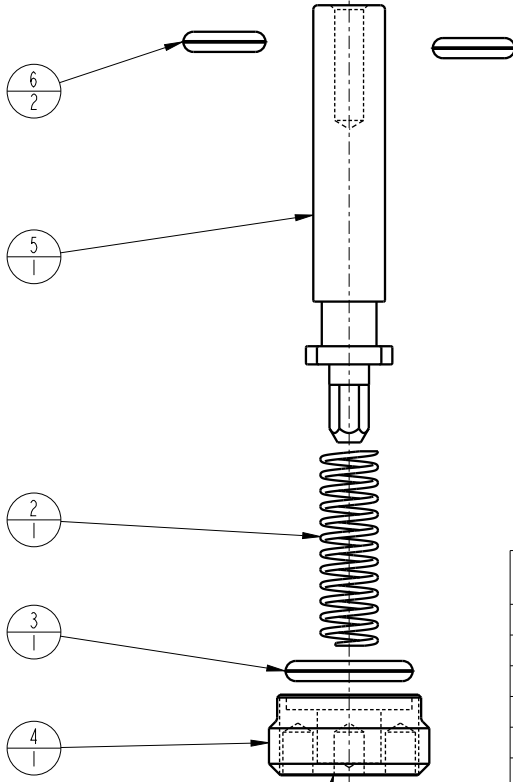
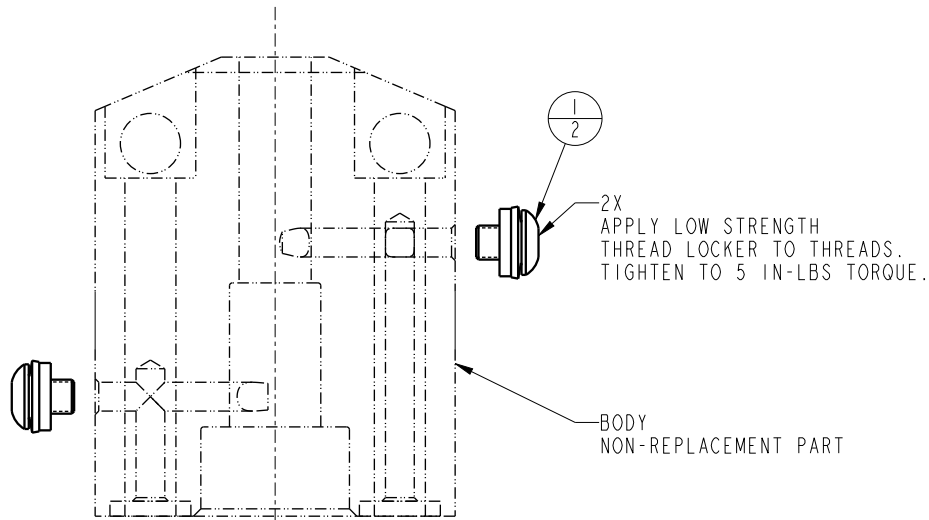

VEKTEK, INC.
 1334 E. SIXTH AVE. P.O. BOX 625
 EMPORIA, KS. 66801 U.S.A.

ASSEMBLIES AFFECTED
 50-4085-01

PARTS LIST, ASSY, SENSOR, POSITION, PNEU, OC

SIZE A
 PL5004

REV E

FORM FEG035_PL_ASIZE, REV. B

E	5164	RELEASE	RLK	8/28/23
REV	IN ACCORDANCE WITH ECN	EFFECTIVE DATE	REVISED BY	DATE
DRW BY:	JDW	DRAWING STATUS: Released		
DATE:	11/03/15	PRODUCTION APPROVED FOR RELEASED STATUS ONLY		

SHEET 1 OF 2

THIS IS A TWO PAGE PARTS LIST.
 THIS SECOND PAGE APPLIES TO
 MODEL 50-4085-01 AT REVISION B AND EARLIER REVISIONS.

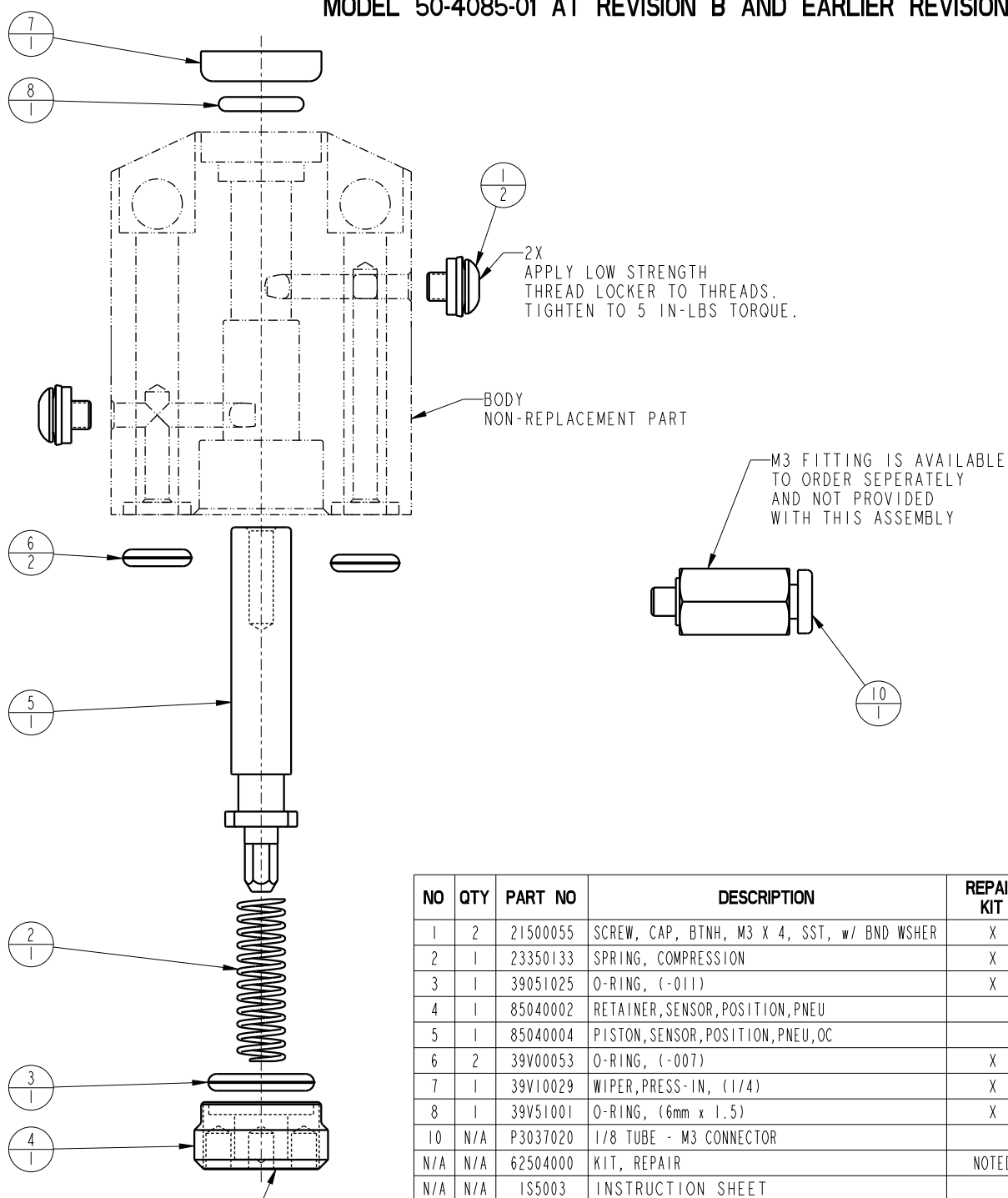

NO	QTY	PART NO	DESCRIPTION	REPAIR KIT
1	2	21500055	SCREW, CAP, BTNH, M3 X 4, SST, w/ BND WSHR	X
2	1	23350133	SPRING, COMPRESSION	X
3	1	39051025	O-RING, (-011)	X
4	1	85040002	RETAINER, SENSOR, POSITION, PNEU	
5	1	85040004	PISTON, SENSOR, POSITION, PNEU, OC	
6	2	39V00053	O-RING, (-007)	X
7	1	39V10029	WIPER, PRESS-IN, (1/4)	X
8	1	39V51001	O-RING, (6mm x 1.5)	X
10	N/A	P3037020	1/8 TUBE - M3 CONNECTOR	
N/A	N/A	62504000	KIT, REPAIR	NOTED
N/A	N/A	IS5003	INSTRUCTION SHEET	

APPLY LOW STRENGTH
 THREAD LOCKER TO THREADS.
 TIGHTEN TO 25 IN-LBS TORQUE.

PARTS LIST	 VEKTEK VEKTEK, INC. 1334 E. SIXTH AVE. P.O. BOX 625 EMPORIA, KS. 66801 U.S.A.
	ASSEMBLIES AFFECTED 50-4085-01
PARTS LIST, ASSY, SENSOR, POSITION, PNEU, OC SIZE A PL5004	REV E SHEET 2 OF 2

E	5164	RELEASE	RLK	8/28/23
REV	IN ACCORDANCE WITH ECN	EFFECTIVE DATE	REVISED BY	DATE
DRW BY:	JDW	DRAWING STATUS: Released		
DATE:	11/03/15	PRODUCTION APPROVED FOR RELEASED STATUS ONLY		